

INSTALLATION GUIDE

Swage Union

Model Type Code: SWUN

Visit www.smartlockfitting.com for video guide

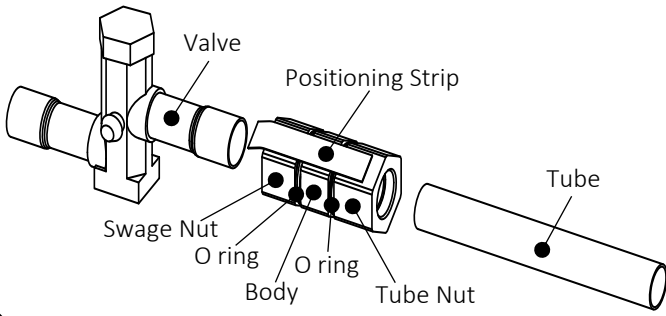

4 Hold the Body then hand tighten the Swage Nut first then the Tube Nut in that order.

Hand tighten to lock swage joint & Tube.

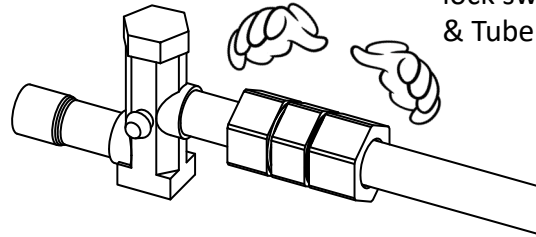

1 Allow the Tube to pass through the fitting.

1 Insert Tube into the swaged part of the service valve.

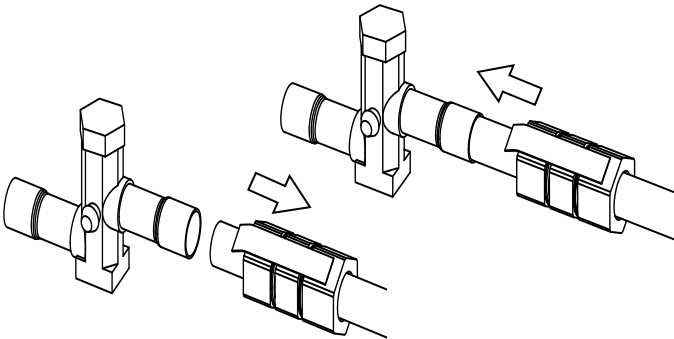

2 Slide the fitting towards the swage tube joint until it stops.

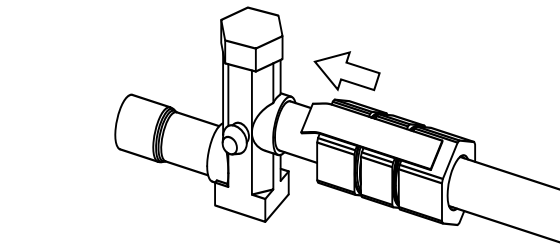

2 Slide the fitting towards the swage tube joint until it stops.

⚠ Be sure to push fitting past any initial resistance from Elastomers until a hard stop against internal shoulder. Bottom it fully.

3 Remove the Positioning Strip.

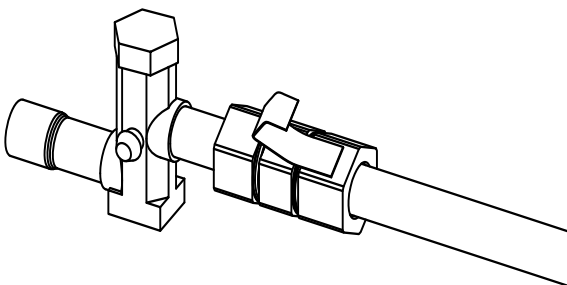

5 With the 1st wrench hold the Body. With the 2nd wrench tighten the Swage Nut first then the Tube Nut until Nuts stop against the Body.

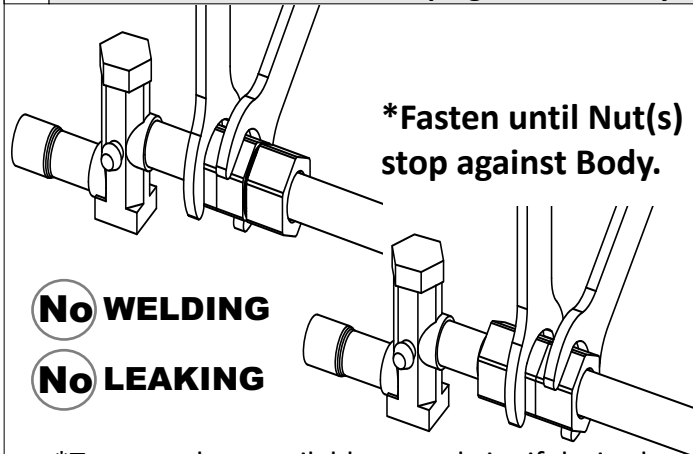

*Torque values available on website if desired

⚠ CAUTION

1. DO NOT REUSE.
2. DO NOT REMOVE POSITIONING STRIP PRIOR TO ASSEMBLY.
3. REMOVE BURRS FROM TUBING WITH CHAMFERING OR DEBURRING TOOL.
4. DO NOT USE DAMAGED TUBE AT 2 INCH FROM THE END OF THE TUBE.
5. DO NOT BEND TUBE AFTER CONNECTION IS MADE.
6. DO NOT USE OTHER THAN FOR INTENDED PURPOSE.



**HVAC/R
Fitting & Valve**

800 Port American Place #100 Grapevine, TX 76502

TEL: 980-333-4530 / FAX: 908-231-2094

sales@smartlockfitting.com

www.smartlockfitting.com